

PART	DESCRIPTION	REQ'D.
A	STEEL FRAME	1 PER UNIT
B	POLYMER GLIDE	4 PER FRAME
C	44" (9944) OR 42" (9942) MOLDED PLY SHELL	2 PER UNIT
D	1/4 - 20UNC X 3' LONG FRONT CONNECTOR BOLT	2 PER SHELL
E	1/4 - 20UNC X 2' LONG REAR CONNECTOR BOLT	2 PER SHELL
F	3/4 DIA. X 1 1/8 LONG BLACK PLASTIC SPACER	2 PER SHELL
G	TABLE TOP	1 PER FRAME
H	#12 X 1' LONG TABLE TOP MOUNTING SCREW	6 PER TABLE TOP

**R** Robertson Furniture Company, Inc.  
 TOCCOA, GEORGIA 30577 TELEPHONE 706-886-1494  
 POST OFFICE BOX 847  
 SCALE: 1 1/2" = 1'-0"  
 DATE: 7-17-1994 DRAWN BY LIVELY  
**WALL STYLE ASSEMBLY INSTRUCTIONS**  
 DRAWING NUMBER: 99WSINST

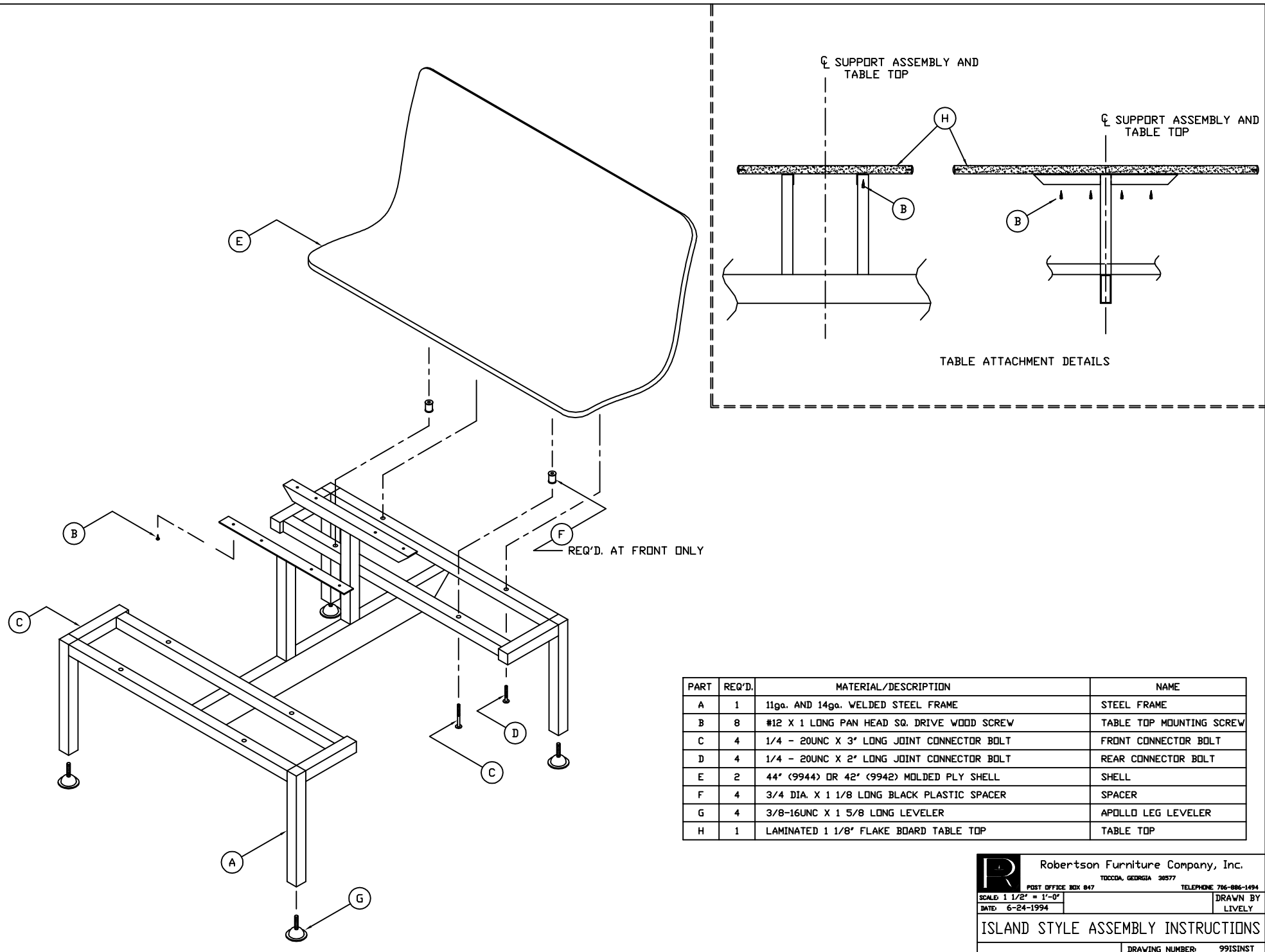

PART	REQ'D.	MATERIAL/DESCRIPTION	NAME
A	1	11ga. AND 14ga. WELDED STEEL FRAME	STEEL FRAME
B	8	#12 X 1 LONG PAN HEAD SQ. DRIVE WOOD SCREW	TABLE TOP MOUNTING SCREW
C	4	1/4 - 20UNC X 3' LONG JOINT CONNECTOR BOLT	FRONT CONNECTOR BOLT
D	4	1/4 - 20UNC X 2' LONG JOINT CONNECTOR BOLT	REAR CONNECTOR BOLT
E	2	44' (9944) OR 42' (9942) MOLDED PLY SHELL	SHELL
F	4	3/4 DIA. X 1 1/8 LONG BLACK PLASTIC SPACER	SPACER
G	4	3/8-16UNC X 1 5/8 LONG LEVELER	APOLLO LEG LEVELER
H	1	LAMINATED 1 1/8' FLAKE BOARD TABLE TOP	TABLE TOP

**R** Robertson Furniture Company, Inc.  
 TOCCOA, GEORGIA 30577  
 POST OFFICE BOX 847 TELEPHONE 706-886-1494

SCALE: 1 1/2" = 1'-0"  
 DATE: 6-24-1994  
 DRAWN BY: LIVELY

ISLAND STYLE ASSEMBLY INSTRUCTIONS

DRAWING NUMBER: 99ISINST